

The "E1" standard ejector handle delivers workhorse performance and durability at an economical price. It is IEEE 1101.1 compliant and can be fitted with hot-swap cable assembly.

"E1" EJECTOR HANDLES	
DESCRIPTION	PART NUMBER
Bottom Ejector Handle	P976A
Bottom Ejector Handle, Hot-Swap	P976-AHS
Top Ejector Handle	P976B
Top Ejector Handle, Hot-Swap	P976-BHS

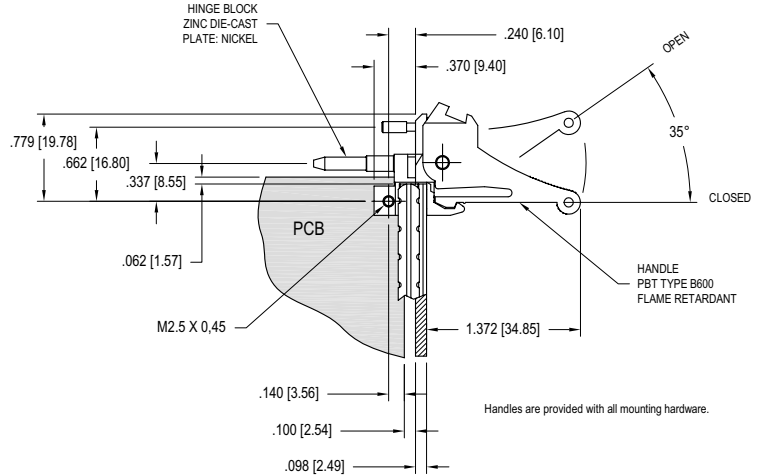
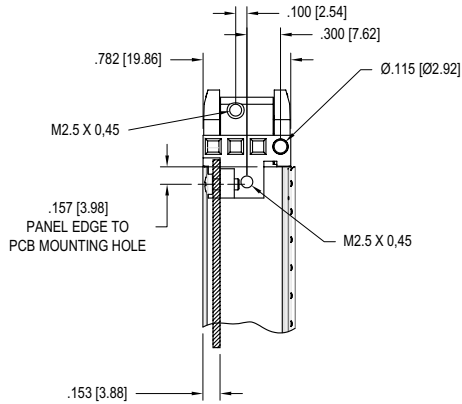

The "Patriot I" latching ejector handle boasts a combination of rotation independent hot-swap operation, robust metal and engineered plastic construction. The patent pending design is highlighted by a nickel plated metal button that eliminates accidental tripping. It is also fully IEEE 1101.1 compliant.

"PATRIOT I" LATCHING EJECTOR HANDLES	
DESCRIPTION	PART NUMBER
Bottom Latching Ejector Handle	P9760-E4-A
Bottom Latching Ejector Handle, Hot-Swap	P9760-E4-AHS
Top Latching Ejector Handle	P9760-E4-B
Top Latching Ejector Handle, Hot-Swap	P9760-E4-BHS

