

cPCI PCB PANELS

LENGTH VALUES ±.003 [.08]

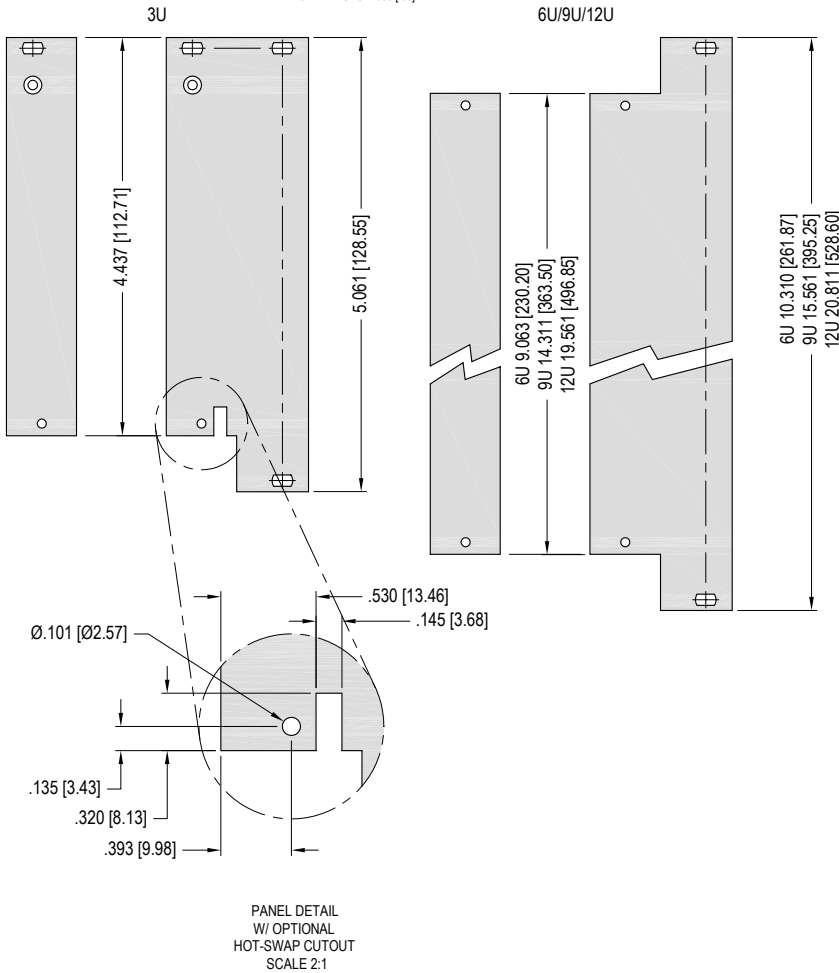

cPCI FILLER PANELS

LENGTH VALUES ±.003 [.08]

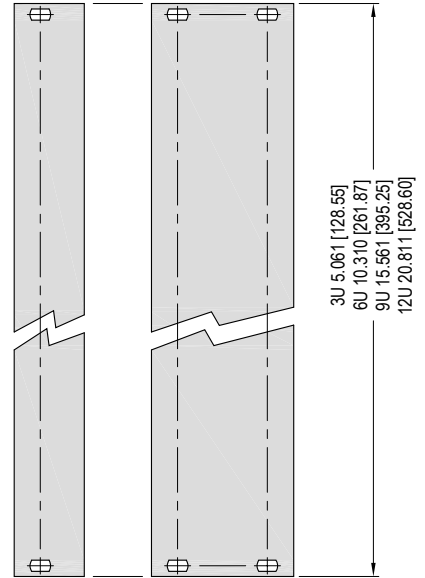

cPCI EXTRUSION SECTION

WIDTH VALUES ±.005 [.13]

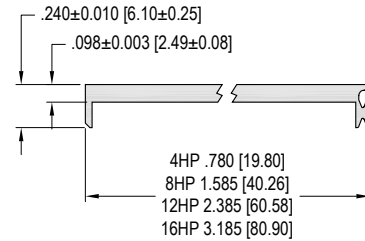

cPCI PANEL PART NUMBERS

	DESCRIPTION	STANDARD PANEL PART NUMBER *
3U	3U X 4HP	P9003-4000C
	3U X 4HP, Hot-Swap	P9003-4000HSC
	3U X 8HP	P9003-8000C
	3U X 8HP, Hot-Swap	P9003-8000HSC
	3U X 12HP	P9003-1200C
	3U X 12HP, Hot-Swap	P9003-1200HSC
	3U X 16HP	P9003-1600C
3U X 16HP, Hot-Swap	P9003-1600HSC	
6U	6U X 4HP	P9006-4000C
	6U X 4HP, Hot-Swap	P9006-4000HSC
	6U X 4HP, 2X Hot-Swap	P9006-4000HS2C
	6U X 8HP	P9006-8000C
	6U X 8HP, Hot-Swap	P9006-8000HSC
	6U X 8HP, 2X Hot-Swap	P9006-8000HS2C
	6U X 12HP	P9006-1200C
	6U X 12HP, Hot-Swap	P9006-1200HSC
	6U X 12HP, 2X Hot-Swap	P9006-1200HS2C
	6U X 16HP	P9006-1600C
	6U X 16HP, Hot-Swap	P9006-1600HSC
	6U X 16HP, 2X Hot-Swap	P9006-1600HS2C

	DESCRIPTION	STANDARD PANEL PART NUMBER *
9U	9U X 4HP	P9009-4000C
	9U X 4HP, Hot-Swap	P9009-4000HSC
	9U X 4HP, 2X Hot-Swap	P9009-4000HS2C
	9U X 8HP	P9009-8000C
	9U X 8HP, Hot-Swap	P9009-8000HSC
	9U X 8HP, 2X Hot-Swap	P9009-8000HS2C
	9U X 12HP	P9009-1200C
	9U X 12HP, Hot-Swap	P9009-1200HSC
	9U X 12HP, 2X Hot-Swap	P9009-1200HS2C
	9U X 16HP	P9009-1600C
9U X 16HP, Hot-Swap	P9009-1600HSC	
9U X 16HP, 2X Hot-Swap	P9009-1600HS2C	
12U	12U X 4HP	P9012-4000C
	12U X 4HP, Hot-Swap	P9012-4000HSC
	12U X 4HP, 2X Hot-Swap	P9012-4000HS2C
	12U X 8HP	P9012-8000C
	12U X 8HP, Hot-Swap	P9012-8000HSC
	12U X 8HP, 2X Hot-Swap	P9012-8000HS2C
	12U X 12HP	P9012-1200C
	12U X 12HP, Hot-Swap	P9012-1200HSC
	12U X 12HP, 2X Hot-Swap	P9012-1200HS2C
	12U X 16HP	P9012-1600C
12U X 16HP, Hot-Swap	P9012-1600HSC	
12U X 16HP, 2X Hot-Swap	P9012-1600HS2C	

cPCI FILLER PANEL PART NUMBERS

	DESCRIPTION	STANDARD PANEL PART NUMBER *
3U	3U X 4HP	P9003-4FC
	3U X 8HP	P9003-8FC
	3U X 12HP	P9003-12FC
6U	6U X 16HP	P9003-16FC
	6U X 4HP	P9006-4FC
	6U X 8HP	P9006-8FC
9U	6U X 12HP	P9006-12FC
	6U X 16HP	P9006-16FC
	9U X 4HP	P9009-4FC
	9U X 8HP	P9009-8FC
9U	9U X 12HP	P9009-12FC
	9U X 16HP	P9009-16FC

Part numbers listed in tables are for blank individual panels only. All cPCI panels are brush finished with 240 grit sand paper and plated per MIL-C-5541, Class III (also referred to as Clear Alodine, Chem Film, or Iridite). Other finishes available upon request.

To order fully assembled panels add "A" to end of part number. For unassembled kits add "K".

CAD files of all panels and assemblies are available upon request.

3U

6U/9U/12U

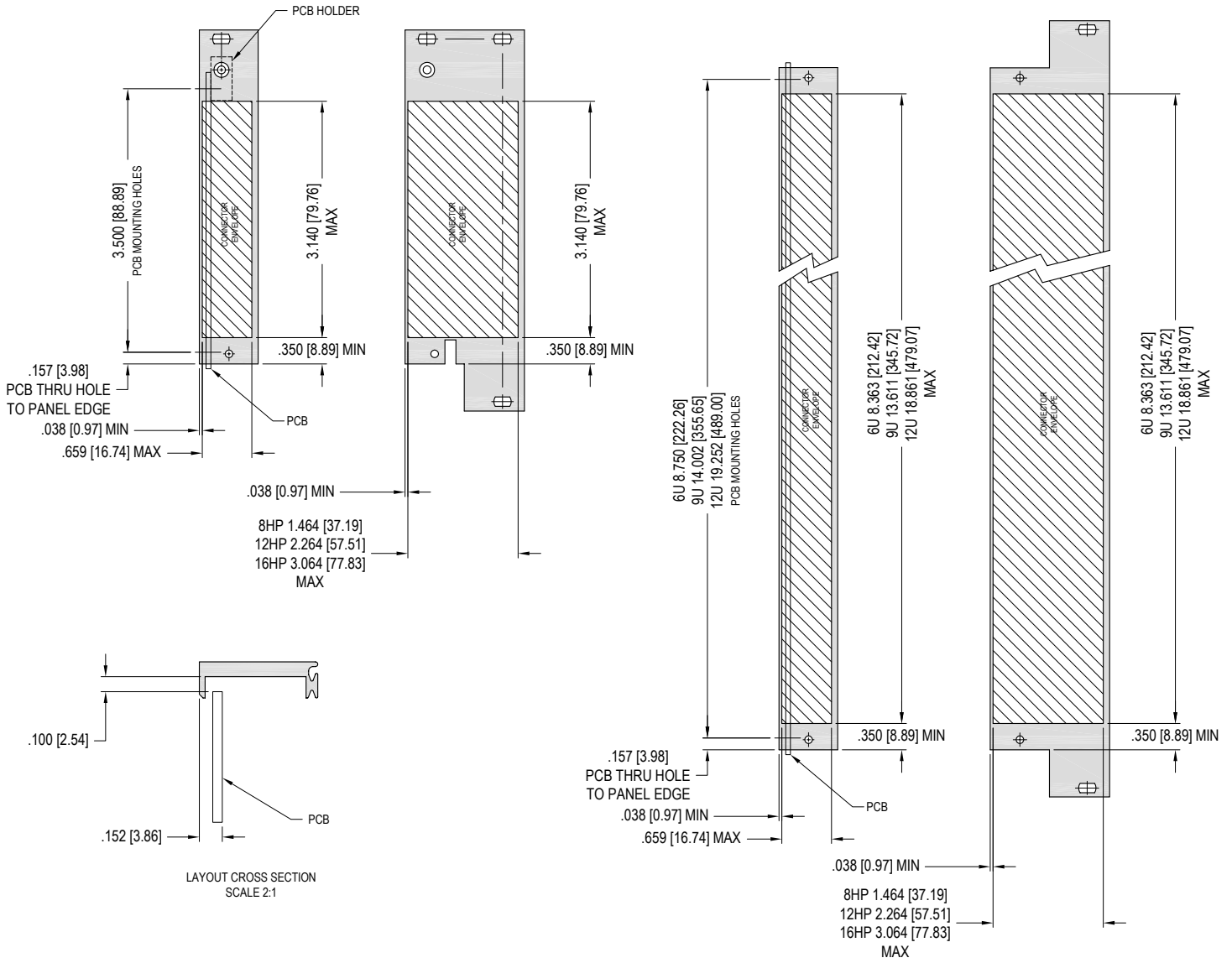

STANDARD PANEL CUTOUTS

SCREW COLLAR CUTOUTS
PRESS FIT

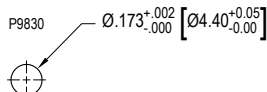
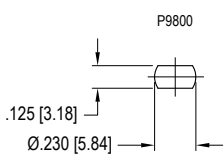

PCB HOLDER MOUNTING HOLE
(P9600)

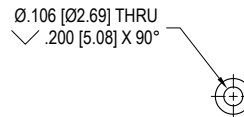

CMC BEZEL CUTOUT
(FROM IEEE P1386)

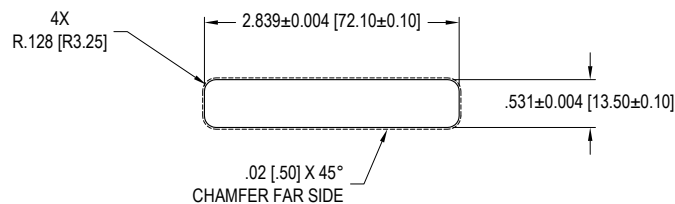

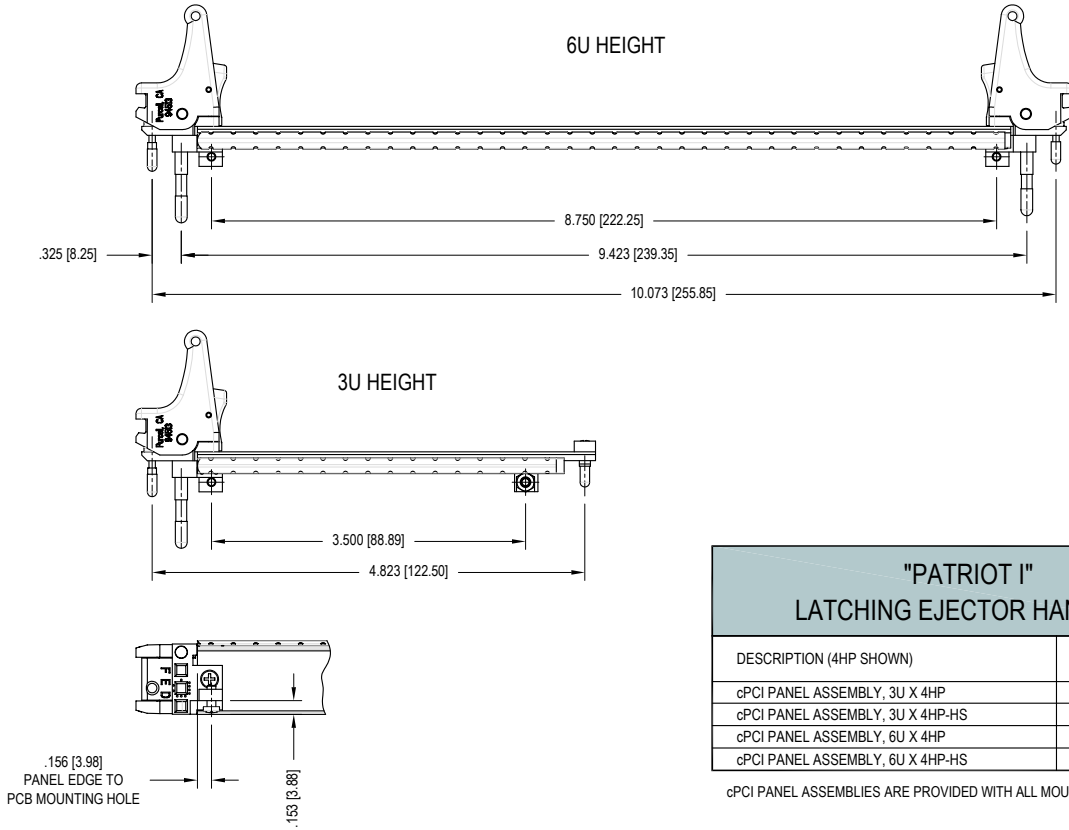





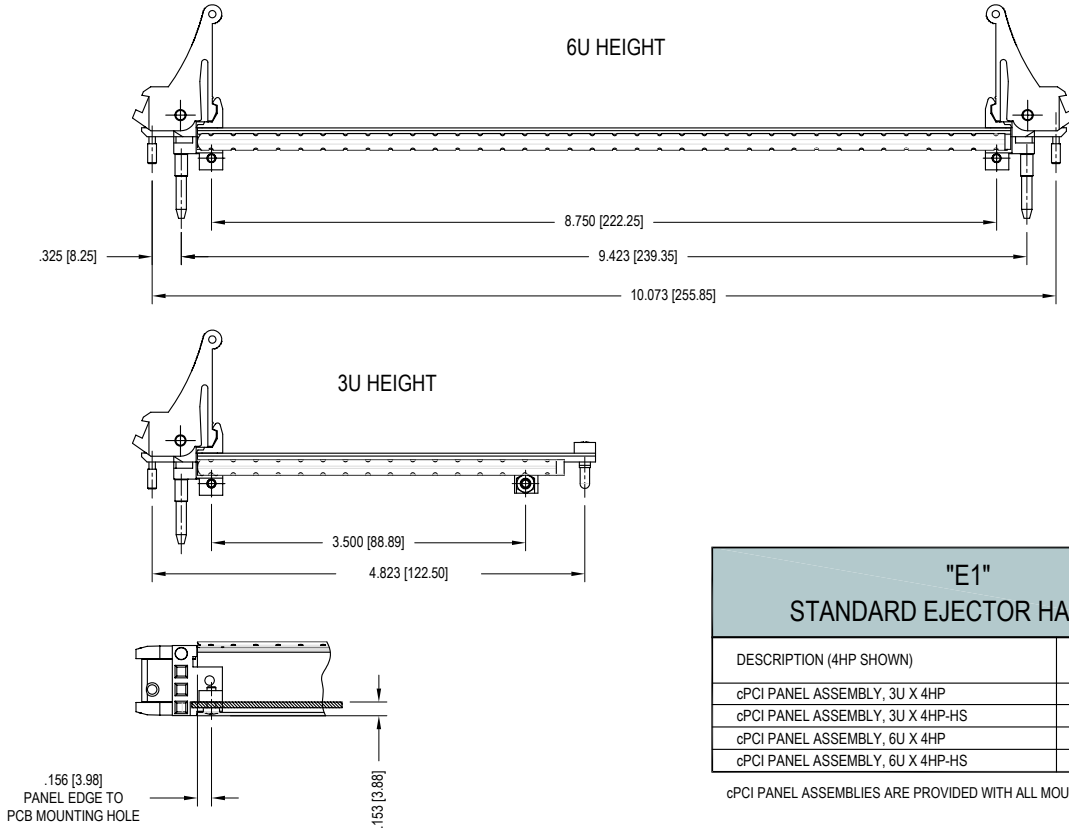

"PATRIOT I" LATCHING EJECTOR HANDLES	
DESCRIPTION (4HP SHOWN)	PART NUMBER
cPCI PANEL ASSEMBLY, 3U X 4HP	PB9003-4000-A
cPCI PANEL ASSEMBLY, 3U X 4HP-HS	PB9003-4000HS-A
cPCI PANEL ASSEMBLY, 6U X 4HP	PB9006-4000-A
cPCI PANEL ASSEMBLY, 6U X 4HP-HS	PB9006-4000HS-A

cPCI PANEL ASSEMBLIES ARE PROVIDED WITH ALL MOUNTING HARDWARE

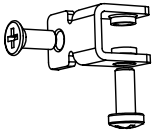
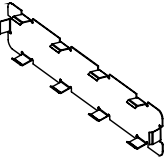
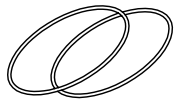
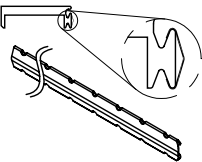

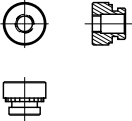
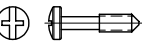
"E1" STANDARD EJECTOR HANDLES	
DESCRIPTION (4HP SHOWN)	PART NUMBER
cPCI PANEL ASSEMBLY, 3U X 4HP	P9003-4000-A
cPCI PANEL ASSEMBLY, 3U X 4HP-HS	P9003-4000HS-A
cPCI PANEL ASSEMBLY, 6U X 4HP	P9006-4000-A
cPCI PANEL ASSEMBLY, 6U X 4HP-HS	P9006-4000HS-A

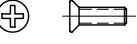
cPCI PANEL ASSEMBLIES ARE PROVIDED WITH ALL MOUNTING HARDWARE

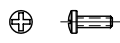
cPCI AND CMC ACCESSORIES		
DESCRIPTION	PART NUMBER	ILLUSTRATION
PCB Holder Nickel Plated CRS	P9600-CRS	
PCB Holder Kitted with Hardware	P9600-CRS-A	
PMC Filler Panel (for vacant pmc cutouts)	P974	
PMC Gasket, Elastomer	P954-046X5.5	
PMC Gasket, BeCu Garter Spring	P9560	
3U EMI Shield, Stainless Steel	P9400	
6U EMI Shield, Stainless Steel	P9410	
9U EMI Shield, Stainless Steel	P9440	
Type 2 EMI Shield, Variable Length SS BeCu	P9450-(length in mm) P9450G-(length in mm)	
M2.5 X 0.45, Captive Screw Collar Cold Drawn Steel, Nickel Plate	P9800	
M2.5 X 0.45, Clinch Nut Style Captive Screw Collar, Cold Drawn Steel, Nickel Plate	P9830	
M2.5 X 0.45, Captive Screw, 11mm	P9710	
M2.5 X 0.45, Pan Head Screw, 6mm	P9720	
M2.5 X 0.45, Flat Head Screw, 8mm	P9610	
M2.5 X 0.45, Hex Nut	P9620	
M2.5 X 0.45, Pan Head Screw, 10mm	P9630	
M1.6 X 0.35, Pan Head Screw, 5mm	P9980	

"E1" EJECTOR HANDLES	
DESCRIPTION	PART NUMBER
Bottom Ejector Handle	P976A
Bottom Ejector Handle, Hot-Swap	P976-AHS
Top Ejector Handle	P976B
Top Ejector Handle, Hot-Swap	P976-BHS

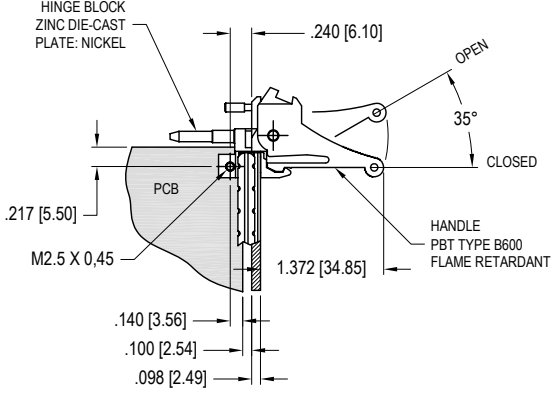

Handles are provided with all mounting hardware.

"PATRIOT I" LATCHING EJECTOR HANDLES	
DESCRIPTION	PART NUMBER
Bottom Latching Ejector Handle	P9760-E4-A
Bottom Latching Ejector Handle, Hot-Swap	P9760-E4-AHS
Top Latching Ejector Handle	P9760-E4-B
Top Latching Ejector Handle, Hot-Swap	P9760-E4-BHS

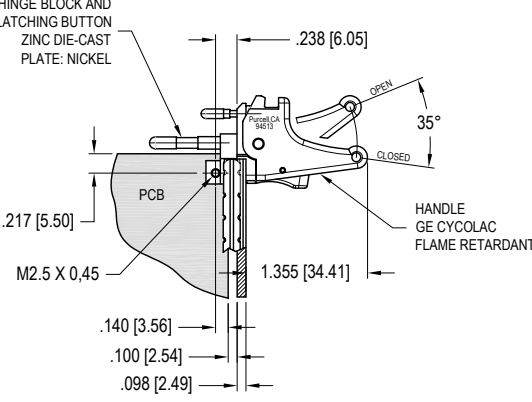

Handles are provided with all mounting hardware.

HOT-SWAP MICROSWITCH CABLE ASSEMBLY DIAGRAM	
DESCRIPTION	PART NUMBER
Hot-Swap Microswitch Cable Assembly	P9990HS
Hot-Swap Microswitch Cable Assembly, with Hardware	P9990HSA

