

PMC BEZEL
MECHANICAL SPECIFICATION

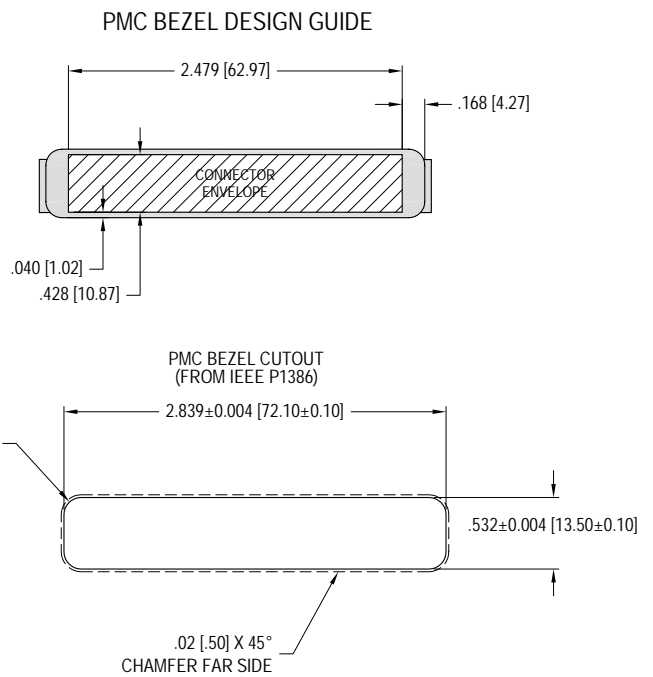
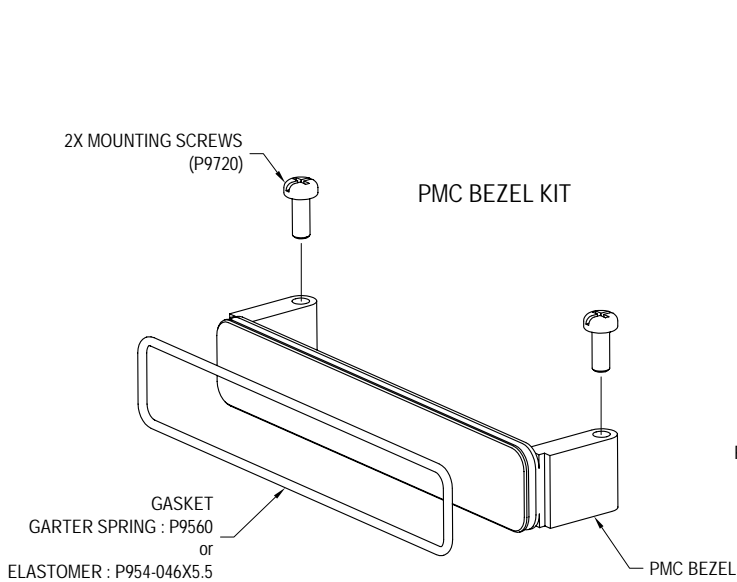
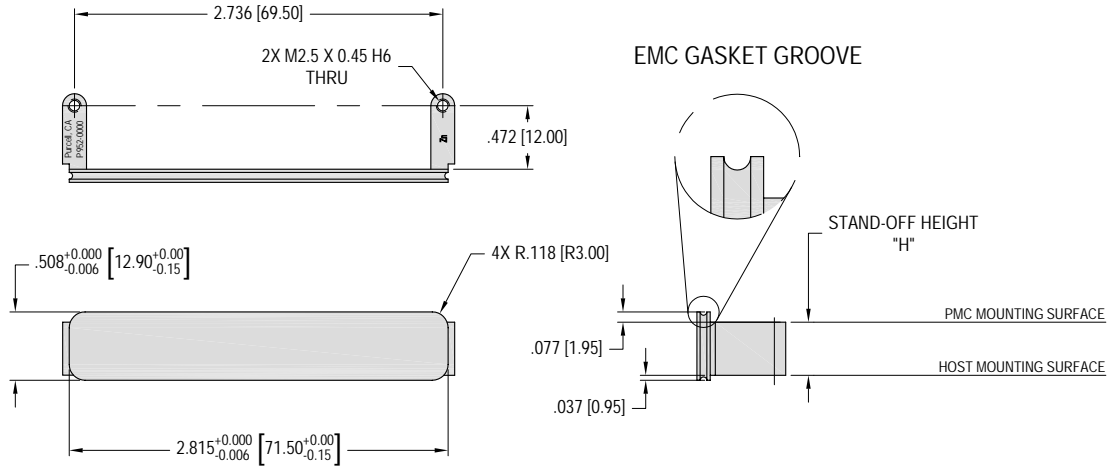

CMC PRODUCT PART NUMBERS					
H	DESCRIPTION	MATERIAL	BEZEL PART NUMBER	KIT - ELASTOMER GASKET PART NUMBER	KIT - GARTER SPRING GASKET PART NUMBER
10mm	PANEL, PMC, 10mm STAND-OFF	ZINC, CHROMIUM PLATED	P952-0000Z	P952-0000Z-KE	P952-0000Z-KG
		ALUMINUM, ALODINE PLATED	P952-0000A	P952-0000A-KE	P952-0000A-KG
11mm	PANEL, PMC, 11mm STAND-OFF	ZINC, CHROMIUM PLATED	P953-0000Z	P953-0000Z-KE	P953-0000Z-KG
		ALUMINUM, ALODINE PLATED	P953-0000A	P953-0000A-KE	P953-0000A-KG